

# MTA

Installation and operating instructions





<b>English (US)</b>	
Installation and operating instructions . . . . .	4
<b>Español (MX)</b>	
Instrucciones de instalación y funcionamiento. . . . .	13
<b>Français (CA)</b>	
Notice d'installation et de fonctionnement . . . . .	23
Appendix 1 . . . . .	32

# English (US) Installation and operating instructions

Original installation and operating instructions.

## CONTENTS

	Page
<b>1. Limited warranty</b>	<b>4</b>
<b>2. Symbols used in this document</b>	<b>5</b>
<b>3. Applications</b>	<b>5</b>
3.1 Pumped liquids	5
<b>4. Identification</b>	<b>5</b>
4.1 Nameplate	5
4.2 Type key	6
<b>5. Operating conditions</b>	<b>6</b>
5.1 Temperatures	6
<b>6. Installation</b>	<b>6</b>
6.1 Mechanical installation	6
6.2 Electrical installation	7
<b>7. Operation</b>	<b>8</b>
7.1 Start-up	8
<b>8. Maintenance and service</b>	<b>8</b>
8.1 Maintenance	8
8.2 Service	8
<b>9. Fault finding</b>	<b>9</b>
<b>10. Technical data</b>	<b>10</b>
10.1 Sound pressure level	10
10.2 Vibration level	10
10.3 Dimensions	10
10.4 Liquid level	11
<b>11. Disposal</b>	<b>12</b>

### **Warning**

***Prior to installation, read these installation and operating instructions. Installation and operation must comply with local regulations and accepted codes of good practice.***



## 1. Limited warranty

Products manufactured by Grundfos Pumps Corporation (Grundfos) are warranted to the original user only to be free of defects in material and workmanship for a period of 24 months from date of installation, but not more than 30 months from date of manufacture. Grundfos' liability under this warranty shall be limited to repairing or replacing at Grundfos' option, without charge, F.O.B. Grundfos' factory or authorized service station, any product of Grundfos manufacture. Grundfos will not be liable for any costs of removal, installation, transportation, or any other charges that may arise in connection with a warranty claim.

Products which are sold, but not manufactured by Grundfos, are subject to the warranty provided by the manufacturer of said products and not by Grundfos' warranty.

Grundfos will not be liable for damage or wear to products caused by abnormal operating conditions, accident, abuse, misuse, unauthorized alteration or repair, or if the product was not installed in accordance with Grundfos' printed installation and operating instructions and accepted codes of good practice. The warranty does not cover normal wear and tear.

To obtain service under this warranty, the defective product must be returned to the distributor or dealer of Grundfos' products from which it was purchased together with proof of purchase and installation date, failure date and supporting installation data. Unless otherwise provided, the distributor or dealer will contact Grundfos or an authorized service station for instructions. Any defective product to be returned to Grundfos or a service station must be sent freight prepaid; documentation supporting the warranty claim and/or a Return Material Authorization must be included if so instructed.

Grundfos will not be liable for any incidental or consequential damages, losses, or expenses arising from installation, use, or any other causes. There are no express or implied warranties, including merchantability or fitness for a particular purpose, which extend beyond those warranties described or referred to above. Some jurisdictions do not allow the exclusion or limitation of incidental or consequential damages and some jurisdictions do not allow limitations on how long implied warranties may last. Therefore, the above limitations or exclusions may not apply to you. This warranty gives you specific legal rights and you may also have other rights which vary from jurisdiction to jurisdiction.

Products which are repaired or replaced by Grundfos or authorized service center under the provisions of these limited warranty terms will continue to be covered by Grundfos warranty only through the remainder of the original warranty period set forth by the original purchase date.

## 2. Symbols used in this document



**Warning**

*If these safety instructions are not observed, it may result in personal injury.*



**Warning**

*If these instructions are not observed, it may lead to electric shock with consequent risk of serious personal injury or death.*



*Notes or instructions that make the job easier and ensure safe operation.*

## 3. Applications

The Grundfos MTA pump is a single-stage centrifugal pump designed for the pumping of cooling lubricants and cutting oil for machine tools.

### 3.1 Pumped liquids

Pump type	Max. particle size [inch (mm)]
MTA 30	0.16 - 0.20
MTA 60	(4 - 5)
MTA 90	0.31 - 0.39
MTA 120	(8 - 10)
MTA 200	
MTA 20H	
MTA 40H	0.16 - 0.20
MTA 70H	(4 - 5)
MTA 100H	

Max. kinematic viscosity [cSt] 90



**Warning**

*Do not use the pump for flammable liquids, such as diesel oil, petrol or similar liquids.*

## 4. Identification

### 4.1 Nameplate

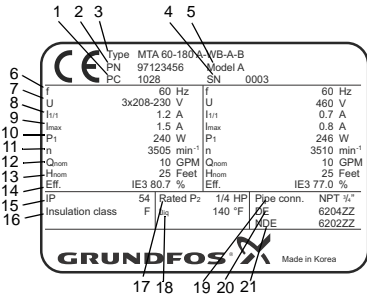

Fig. 1 Example of nameplate

Pos.	Description
1	Production code ((YYWW))
2	Product number
3	Type designation (see 4.2 Type key)
4	Serial number
5	Model
6	Frequency
7	Supply voltage
8	Full-load current
9	Maximum current
10	Motor input power
11	Rated speed
12	Rated flow
13	Rated head
14	Efficiency class (applies only to MTA 200)
15	Motor enclosure class
16	Motor insulation class
17	Rated motor output power
18	Maximum temperature of pumped liquid
19	Pipe connection
20	Motor drive-end bearing
21	Motor non-drive-end bearing

TM05 1 444 2711

## 4.2 Type key

<b>Example</b>	<b>MTA 60 H -180 -A -WB -A -B</b>
Type range	
Rated flow [l/min]	
Pressure type	
Installation length [mm]	
<b>Pump version</b>	
A = Standard version	
<b>Thread type</b>	
WB = Internal NPT thread	
W = Internal Rp thread	
<b>Impeller material</b>	
A = PAA GF50	
B = Bronze	
<b>Suction</b>	
T = Top	
B = Bottom	

## 5. Operating conditions

### 5.1 Temperatures

Permissible liquid temperature [°F (°C)]	+32 to +140 (0 to +60)
Maximum permissible ambient temperature during operation [°F (°C)]	+104 (+40)
Permissible ambient temperature during storage [°F (°C)]	-58 to +158 (-50 to +70)

## 6. Installation



### Warning

Position the pump so that persons cannot accidentally come into contact with hot surfaces.



### Warning

Position the pump so that persons cannot accidentally come into contact with the rotating parts.

## 6.1 Mechanical installation

### 6.1.1 Pump position



**MTA pumps can only be mounted in the vertical position.**

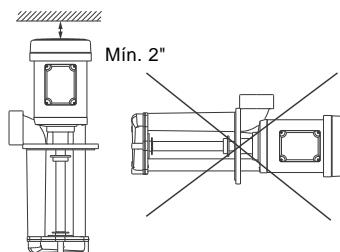

**Fig. 2** Correct mounting position

The pump is designed for tank mounting in the vertical position. The pump is positioned in a hole cut into the cover of the tank (upper side) and secured to the tank by hexagon head screws through the holes in the mounting flange. We recommend to fit a sealing gasket between pump flange and tank.

For ventilation and cooling, leave a clearance of minimum 2" (50 mm) above the motor.

The pump is designed for indoor operation only. Do not spray liquids directly on the motor.

### 6.1.2 Terminal box positions

The terminal box of most of the MTA pump types can be turned to another position after delivery. See the table below.

Pump type	Terminal box positions	
	9 o'clock (standard)	3 o'clock
MTA 30	•	•
MTA 60	•	•
MTA 90	•	•
MTA 120	•	(•)
MTA 200	•	(•)
MTA 20H	•	•
MTA 40H	•	•
MTA 70H	•	•
MTA 100H	•	(•)

- The terminal box can be turned to another position after delivery.
- (•) The terminal box cannot be turned to another position after delivery.

## 6.2 Electrical installation

### 6.2.1 Electrical connection

Carry out the electrical connection according to local regulations.

Check that the supply voltage and frequency correspond to the values stated on the nameplate.



#### Warning

**Before making connections in the pump terminal box, make sure the power supply has been switched off.**

The operating voltage and frequency are marked on the pump nameplate. Make sure that the motor is suitable for the power supply available.

The motor must be connected to a motor-protective circuit breaker.

We do not recommend operation via frequency converter.

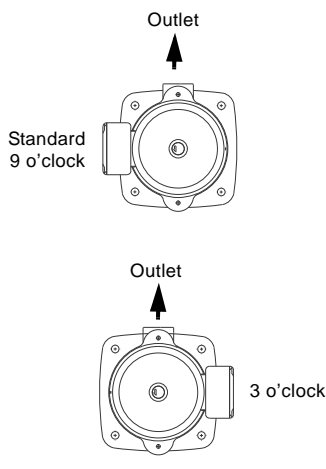

TM05 1759 3611

TM05 1760 3611

**Fig. 3** Possible terminal box positions (top view)

To turn the terminal box to another position, do as follows:

1. Remove the bolts securing the motor to the pump.
2. Turn the motor to the required position.
3. Refit and tighten the bolts securing the motor to the pump.

Connect the electric motor to the power supply as shown in the diagram in the terminal box cover.

## 7. Operation

### 7.1 Start-up

The pump can be started against an open or a closed discharge valve.

#### Before starting the pump:

- Make sure that all pipe connections are tight.
- Make sure that the pump is immersed to the recommended level.
- Make sure that chip trays are not blocked by impurities.

#### Start the pump as follows:

1. See the correct direction of rotation of the pump on the motor fan cover or on the sight glass. When seen from the top, the pump should rotate counter-clockwise.
2. Start the pump and check the direction of rotation.

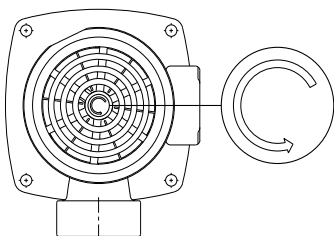

Fig. 4 Motor fan cover with indication of the correct direction of rotation

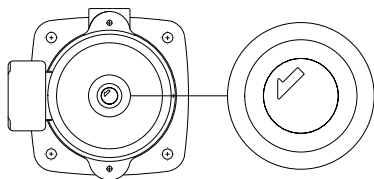

Fig. 5 Sight glass with indication of the correct direction of rotation

TM04 8004 2610

TM04 8003 2610

## 8. Maintenance and service

### 8.1 Maintenance

Pumps installed in accordance with these instructions require very little maintenance.

#### 8.1.1 Lubrication

The motor ball bearings are grease-packed and sealed for life. No further lubrication is necessary.

#### 8.1.2 Filters

Chip trays, filters, etc. should be cleaned at regular intervals to ensure a correct flow of liquid. This will also increase the pump life.

#### 8.1.3 Periodic checks

Make the following checks at regular intervals, depending on the conditions and time of operation.

- Check the quantity of liquid and operating pressure.
- Check that there are no leaks.
- Check that the motor is not overheating.
- Check the tripping of the motor-protective circuit breaker.
- Check that all control devices are operating satisfactorily.

If the above checks do not reveal any abnormal operating details, no further checks are necessary.

Should any faults be found, see section 9. *Fault finding.*

### 8.2 Service

#### 8.2.1 Contaminated pumps

##### Warning



***If used for a liquid which is injurious to health or toxic, the pump will be classified as contaminated.***

Before the pump is returned to Grundfos for service, the certificate of cleanliness must be filled in and sent to Grundfos. See page 10. If Grundfos is requested to service the pump, it must be cleaned before it is returned.

If the above is not fulfilled, Grundfos can refuse to accept the pump for service. Possible costs of returning the pump are to be paid by the customer.



## 9. Fault finding



### Warning

*Before starting fault finding, switch off the power supply.  
Make sure that the power supply cannot be accidentally switched on.*

Fault	Cause	Remedy
1. Motor does not run when power supply is switched on.	a) Supply failure.	Connect the power supply.
	b) Fuses are blown.	Replace the fuses.
	c) Motor-protective circuit breaker has tripped.	Reactivate the motor protection.
	d) Main contacts in motor-protective circuit breaker are not making contact or the coil is faulty.	Replace the contacts or the magnetic coil.
	e) Control circuit is defective.	Repair the control circuit.
	f) Motor is defective.	Replace the pump.
2. Motor-protective circuit breaker trips immediately when power supply is switched on.	a) Fuse on one phase is blown.	Replace the fuse.
	b) Contacts in motor-protective circuit breaker are faulty.	Replace the contacts in the motor-protective circuit breaker.
	c) Cable connection is loose or faulty.	Fasten or replace the cable connection.
	d) Motor winding is defective.	Replace the pump.
	e) Pump mechanically blocked.	Remove the mechanical blocking of the pump.
	f) Overload setting is too low.	Set the motor-protective circuit breaker correctly.
3. Motor-protective circuit breaker trips occasionally.	a) Overload setting is too low.	Set the motor-protective circuit breaker correctly.
	b) Low voltage at peak times.	Check the power supply.
4. Motor-protective circuit breaker has not tripped, but the pump does not run.	a) Check 1 a), b), d) and e).	
5. Pump runs, but gives no liquid, or pump capacity is not constant.	a) Pump inlet partly blocked by impurities.	Clean the inlet.
	b) Liquid level in tank is too low.	Increase the liquid level.
	c) Pump rotates in the wrong direction.	Change the direction of rotation of the motor by switching any two of the phases.

## 10. Technical data

Enclosure class to IEC 60034-5	IP54
Insulation class	F
Maximum voltage fluctuation to IEC 60034	± 10 %
Recommended maximum number of starts per hour	250

**Note**

Pay attention to potential condensation problems in humid areas.

### 10.1 Sound pressure level

Pump type	Rated P2 [W]	L <sub>pA</sub> [dB(A)]
		60 Hz
MTA 30	100	< 45
MTA 60	180	< 45
MTA 90	250	< 45
MTA 120	400	< 62
MTA 200	750	< 62
MTA 20H	100	< 45
MTA 40H	180	< 45
MTA 70H	250	< 45
MTA 100H	400	< 62

### 10.2 Vibration level

Vibration velocity RMS < 0.07 in/s (1.8 mm/s).

Vibration according to ISO 10816-1 class IB.

## 10.3 Dimensions

### 10.3.1 Installation dimensions

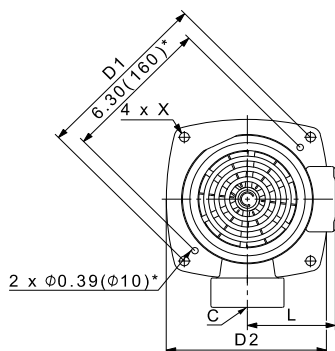

TM05 1466 2711

\* Applies only to MTA 120

Fig. 6 Installation dimensions

Pump type	C	D1 [inch]	D2 [inch (mm)]	L [inch (mm)]	X Ø [inch]
MTA 30	1/2" NPT	5.20 (132)	4.57 (116)	3.94 (100)	0.27 (7)
MTA 60	3/4" NPT	6.30 (160)	5.63 (143)	4.43 (112.5)	0.39 (10)
MTA 90	3/4" NPT	6.30 (160)	6.06 (154)	4.43 (112.5)	0.39 (10)
MTA 120	1 1/4" NPT	7.09 (180)	6.10 (155)	4.98 (126.5)	0.39 (10)
MTA 200	1 1/2" NPT	8.66 (220)	7.87 (200)	5.30 (134.5)	0.47 (12)
MTA 20H	1/2" NPT	5.20 (132)	4.57 (116)	3.94 (100)	0.27 (7)
MTA 40H	3/4" NPT	6.30 (160)	5.63 (143)	4.43 (112.5)	0.39 (10)
MTA 70H	3/4" NPT	6.30 (160)	6.06 (154)	4.43 (112.5)	0.39 (10)
MTA 100H	1" NPT	7.09 (180)	6.89 (175)	4.88 (124)	0.39 (10)

### 10.3.2 Tank hole and cable entry hole dimensions

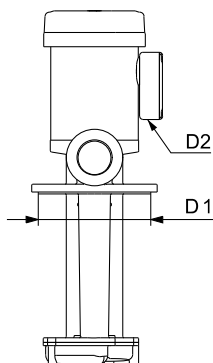
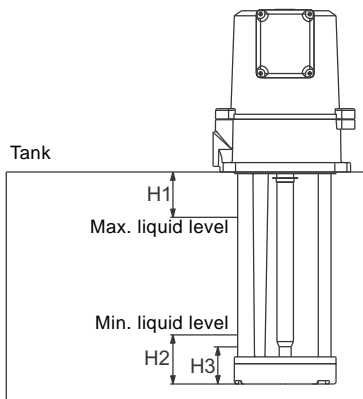

**Fig. 7** Tank hole and cable entry hole dimensions

Pump type	Tank hole	Cable entry hole
	D1 Ø [inch (mm)]	D2 Ø [inch (mm)]
MTA 30	3.94 (90)	0.87 (22)
MTA 60	4.52 (115)	0.87 (22)
MTA 90	5.04 (128)	0.87 (22)
MTA 120	5.31 (135)	0.87 (22)
MTA 200	7.09 (180)	0.87 (22)
MTA 20H	3.94 (100)	0.87 (22)
MTA 40H	5.31 (135)	0.87 (22)
MTA 70H	5.31 (135)	0.87 (22)
MTA 100H	6.10 (155)	0.87 (22)

### 10.4 Liquid level

#### 10.4.1 MTA with top suction



**Fig. 8** MTA with top suction

Pump type	H1 [inch (mm)]	H2 * [inch (mm)]	H3 ** [inch (mm)]
MTA 30	0.59 (15)	2.36 (60)	1.97 (50)
MTA 60	0.79 (20)	2.76 (70)	1.77 (45)
MTA 90	0.79 (20)	3.35 (85)	2.28 (58)
MTA 120	0.79 (20)	4.33 (110)	2.76 (70)
MTA 20H	0.59 (15)	1.97 (50)	1.57 (40)
MTA 40H	0.79 (20)	2.76 (70)	1.57 (40)
MTA 70H	0.79 (20)	3.15 (80)	1.97 (50)
MTA 100H	0.79 (20)	4.34 (110)	2.36 (60)

\* Min. liquid level (full performance)

\*\* Min. permissible liquid level (reduced performance)

TM05 0632 1311

TM04 7992 4211

## 10.4.2 MTA with bottom suction

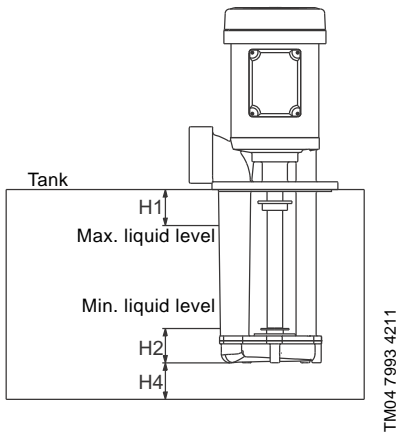

Fig. 9 MTA with bottom suction

Pump type	H1 [inch (mm)]	H2 * [inch (mm)]	H4 [inch (mm)]
MTA 30	0.59 (15)	0.79 (20)	0.39 (10)
MTA 60	0.79 (20)	0.79 (20)	0.39 (10)
MTA 90	0.79 (20)	0.98 (25)	0.59 (15)
MTA 120	0.79 (20)	0.98 (25)	0.79 (20)
MTA 200	0.98 (25)	0.98 (50)	1.18 (30)

\* Min. liquid level (full performance)

## 11. Disposal

This product or parts of it must be disposed of in an environmentally sound way:

1. Use the public or private waste collection service.
2. If this is not possible, contact the nearest Grundfos company or service workshop.

Subject to alterations.

## Appendix

## Certificate of cleanliness

BE <b>▶</b> THINK <b>▶</b> INNOVATE <b>▶</b>		GRUNDFOS <b>Certificate of Cleanliness Health and Safety Clearance Form</b>
--	---	--

Please provide all pertinent information

Product Description _____
Product Number _____ Quantity _____

## APPLICATION

The referenced product has been exposed to toxic or hazardous materials: YES  NO   
If yes, complete SECTION A. If no, continue to SECTION B.

### SECTION A: TOXIC CLEARANCE

*(To be completed if applied substances are hazardous)*

Please specify all hazardous materials/substances used with the referenced product(s).

\_\_\_\_\_

\_\_\_\_\_

Provide the Material Safety Data Sheet for all materials referenced or list precautions to be taken when handling these substances. Also, provide any actions to be taken in the event of human contact with any liquid within the product (even after cleaning and/or flushing).

\_\_\_\_\_

\_\_\_\_\_

The product returned has been decontaminated, drained of liquid and is safe to handle. Provide decontamination method used.

\_\_\_\_\_

\_\_\_\_\_

\_\_\_\_\_ Initial/Date \_\_\_\_\_

### SECTION B: NON-TOXIC CLEARANCE

*(To be completed if applied substances are not hazardous)*

The product returned has not handled or been in contact with any toxic or hazardous substances. The product has been drained of liquid and is safe to handle.

\_\_\_\_\_

\_\_\_\_\_

\_\_\_\_\_ Initial/Date \_\_\_\_\_

I hereby declare that the contents of this consignment are fully and accurately described above by proper shipping name and are classified, packed, marked and labeled, and are in all respects in proper condition for transport, by all modes, according to applicable international and national governmental regulations. Health and safety issues are clearly understood and will be given consideration during shipment. (A repair or inspection of product will only be undertaken when this certificate has been completed and authorized by a qualified member of staff employed by the returning company.)

COMPANY NAME \_\_\_\_\_

NAME \_\_\_\_\_ POSITION \_\_\_\_\_

SIGNATURE \_\_\_\_\_ PHONE \_\_\_\_\_

**Radioactive products will not be accepted for repair.** A return material authorization number from Grundfos, along with a completed and signed copy of this form must accompany the returned product. It is the sender's responsibility to package, transport and complete the shipping documents regarding the nature of the product shipped. Irrespective of this, Grundfos reserves the right to reject the service order for other reasons. Grundfos will rely on this representation and will look to the customer for reimbursement of any and all costs, claims or damages incurred, including attorney's fees, if any representation is not correct.

Grundfos Pumps Corporation  
17100 W. 118th Terrace  
Olathe, Kansas 66062  
Telephone: 913.227.3400  
Fax: 913.227.3500  
www.grundfos.com

L-CC-FRM-002 Rev. 08/03  
PRINTED IN USA

**GRUNDFOS** 





**USA**

GRUNDFOS Pumps Corporation  
17100 West 118th Terrace  
Olathe, Kansas 66061  
Phone: +1-913-227-3400  
Telefax: +1-913-227-3500

**Canada**

GRUNDFOS Canada Inc.  
2941 Brighton Road  
Oakville, Ontario  
L6H 6C9  
Phone: +1-905 829 9533  
Telefax: +1-905 829 9512

**México**

Bombas GRUNDFOS de México S.A.  
de C.V.  
Boulevard TLC No. 15  
Parque Industrial Stiva  
Aeropuerto  
Apodaca, N.L.C.P. 66600  
Phone: +52-81-8144 4000  
Telefax: +52-81-8144 4010



L-MT-TL-002

<b>98097625</b> 0212
----------------------

ECM: 1083022
--------------

© 2012 Grundfos Pumps Corp.

The name Grundfos, the Grundfos logo, and the payoff Be-Think-Innovate are registered trademarks owned by Grundfos Management A/S or Grundfos A/S, Denmark. All rights reserved worldwide.